

Determination of Pesticides in Aqueous Samples by On-Line Coupling Solid-Phase Extraction to Gas Chromatography with At-Column Concentrating Interface

Ryoichi Sasano*, Takayuki Hamada, Masahiro Furuno

GL Sciences, 237-2 Sayamagahara, Iruma, Saitama, 358-0032 Japan

Key Words: On-line SPE-GC; Large volume injection; Determination of Pesticides in water

Summary

The on-line automatic Solid Phase Extraction and the capillary GC/MS were combined for the determination of pesticides and herbicides in the aqueous samples. The at-column concentrating large volume injection method which the authors exploited was employed as the interface between SPE and GC/MS. In the at-column concentrating large volume injection method, the sample solvent was evaporated in the empty liner and the target compounds were retained at the inlet of the analytical GC capillary column. Employing this method, heat labile target compounds were not decomposed. Automatic on-line operation was possible, since the large volume of the liquid sample could be transferred to the capillary GC/MS system.

1 Introduction

Recently, water pollution caused by pesticides and herbicides have become one of the serious environmental pollution. Therefore, the government regulations of water pollution due to pesticides and herbicides have become strict for protecting human health. In the conventional methods for the determination of pesticides and herbicides contained in the tap water and the river or lake water, solid phase extraction sample preparation prior to GC/MS analysis has been employed. However, the manual sample preparation methods are likely to cause human errors and require operators technical skills.

In this study, we connected the ProspektTM (Spark Holland); automatic on-line solid phase extraction instrument and GC/MS equipped with OPTICTM 2-200 PTV (ATAS Netherland) for at-column concentrating large volume injection system. We employed the at-column concentrating large volume injection method as the interface between SPE and GC/MS. Using this method, we could

connect the automatic SPE and GC/MS without causing the degradation of target compounds. We have examined how to determine 30 kinds of pesticide and herbicide compounds in the aqueous samples, using this system.

2 Experimental

2.1 Chemicals and reagents

All the standard compounds of pesticides and herbicides were from GL Sciences. Acetone and methanol of pesticide residue analysis grade were purchased from Kishida Chemical Co.. The stock solutions of the standards were prepared by diluting 500 mg of each standard compounds in 50 ml acetone. The solution was diluted into 0.1 mg/L using acetone. The standard solution was spiked into the purified water as the concentration of 1 g/L. 30 kinds of pesticides and herbicides we used here were those which are to be determined using GC, specified by Japanese national government regulation.

2.2 SPE instrument

The automatic on-line SPE instrument; Prospekt (Spark Holland) was connected with the autosampler; MIDAS™ (Spark Holland). The 2 mL stainless steel sample loop was installed to the sampling valve of the MIDAS. The solid phase extraction cartridge employed for the Prospekt was PLRP-S, 2.0 mm i.d.~10 mm length, 15 - 25 μm particle diameter. The HPLC pump PU610 (GL Sciences) was employed for eluting the target compounds from the SPE cartridge. The outlet of SPE valve and the GC injector are connected using a 0.25 mm i.d.~0.5 m length inactivated capillary tube. The schematic flow diagram of this automated SPE system is shown in Fig. 1.

2.3 GC instrument

GC instrument used was HP6890 (Hewlett Packard) equipped with OPTIC 2-200 PTV injector (ATAS Netherland). The liner used was the liner for at-column concentrating large volume injection

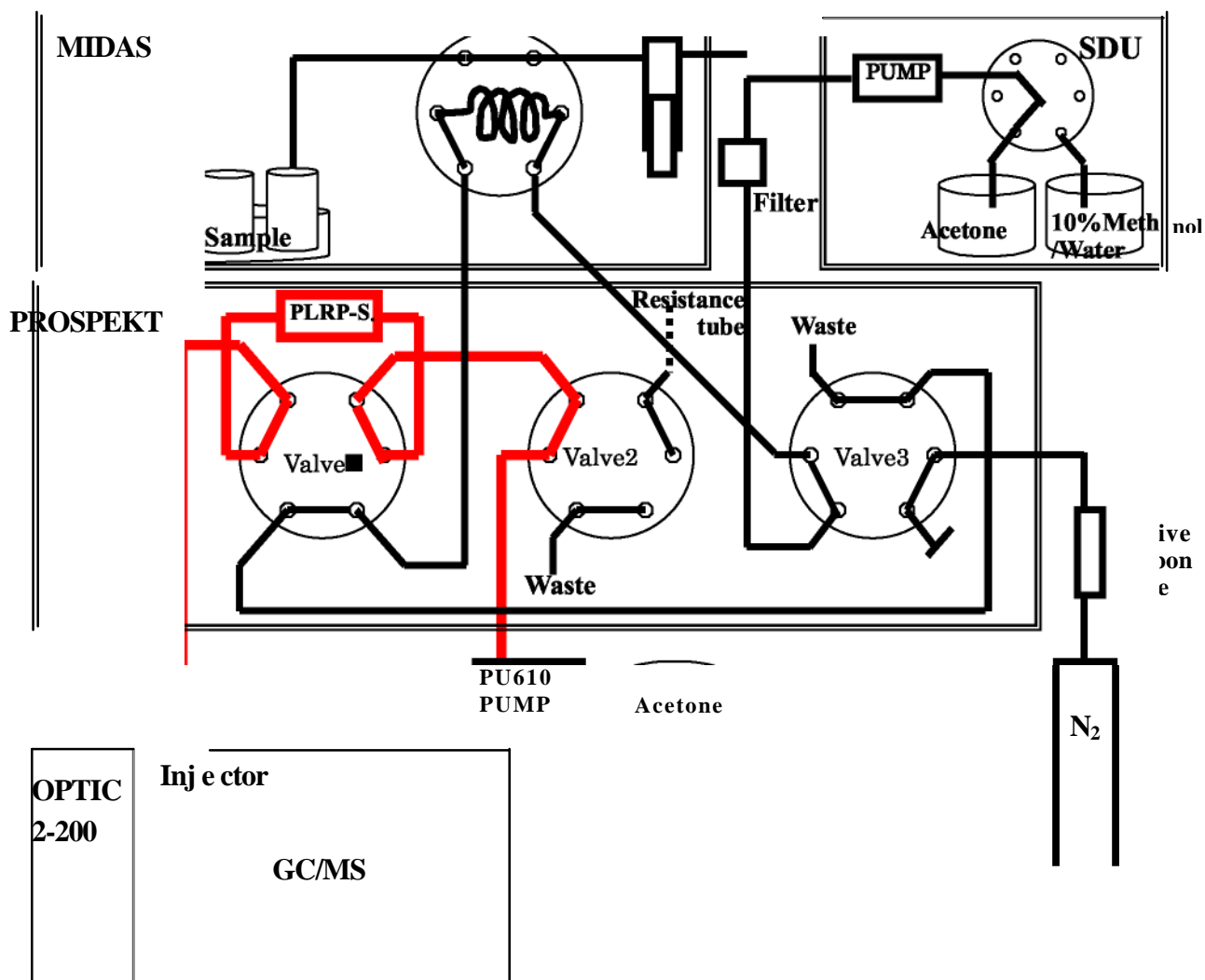

Fig. 1 Schematic flow diagram of automated on-line SPE system, consisting of MIDAS auto-sampler, SDU and Prospekt

(GL Sciences), MS used was HP 5973 (Hewlett Packard), Pre-column used was the inactivated capillary tube; 0.53 mm i.d.~ 0.3 m length (GL Sciences). The analytical capillary column was NB-5 0.25 mm i.d.~ 30 m length, film thickness; 0.4 μm (GL Sciences). The pre-column and the analytical capillary column are connected using the press-fit connector.

2.4 Operating procedure

2 mL sample solution was injected to the SPE cartridge employing MIDAS. The SPE cartridge was pre-conditioned using acetone and then (10 % methanol / 90 % water) mixture prior to the sample

loading. After loading the sample and washing the cartridge, the SPE cartridge was N₂ gas purged for eliminating the remaining water in the cartridge. Then, the target compounds were eluted from the SPE cartridge, using approximately 30 L acetone at the flow rate of 100 L/min. The eluted compounds were injected to the capillary GC/MS system automatically. The GC/MS system was operated using SIM mode. The operating conditions of GC/MS are shown in Table 1.

Table 1 Operating conditions of GC/MS and Opric 2-200

Oven Temp	73~(1 min) - 15~/min - 210~ - 4~/min - 250~ - 20~/min - 280~(6min)
Interface Temp	280 ~ MS
Source Temp	230 ~ MS Quad
Temp	150 ~
Method	SIM
Injector	Optic 2-200 (At-column concentrating Liner)
Injection Method	Large Volume Method
Vent Time	AUTO
Initial Temp	62 ~
Ramp rate	1 ~/s
Final Temp	280 ~
Split open Time	0 min
Purge pressure	25 kPa
Transfer Time	1 min
Initial pressure	50 kPa
Final pressure	200 kPa
Solvent threshold	15

3 Results and discussion

3.1 Interface

In this study, we employed the at-column concentrating large volume injection method. The scheme of this method is described as follows.

The temperature of the injector was set at lower than the boiling point of the sample solvent and the column oven temperature was set at higher than the boiling point of the sample solvent. The sample solution is injected into the liner shown in Fig. 2. The liquid solvent stayed in the liner, since the